

92 PCB pushbuttons

Pushbutton actuator IP 40

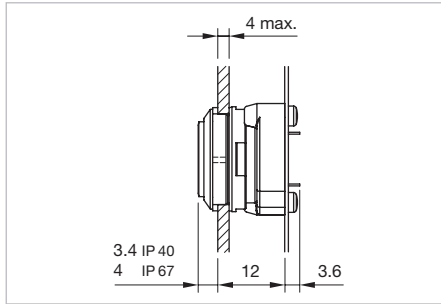

Product can differ from the current configuration.





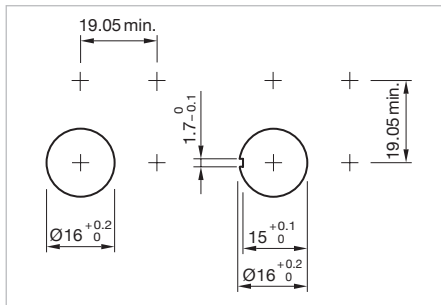



Dimensions



Mounting cut-outs

Equipment consisting of (schematic overview)

-  **Lens** page 14
-  **Actuator**
-  **Bezel** page 15
-  **Fixing nut**
-  **Mounting flange** page 19
-  **Switching element** page 16

Each Part Number listed below includes all the black components shown in the 3D-drawing.

To obtain a complete unit, please select the red components from the pages shown.





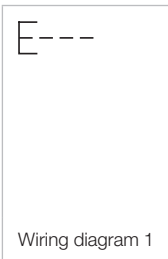

Front	Switching action	Part No.	Wiring diagram	Weight
				
Pushbutton actuator IP 40, Front dimension 18.4 x 18.4 mm				
Plastic white	B	92-350.000	1	0.003 kg
Plastic black	B	92-450.000	1	0.003 kg

Switching action: B = Momentary



Pushbutton actuator IP 67

Equipment consisting of (schematic overview)

-  **Pressure plate** *page 14*
-  **Front bezel**
-  **Actuator**
-  **Fixing nut**
-  **Mounting flange** *page 19*
-  **Switching element** *page 16*

Each Part Number listed below includes all the black components shown in the 3D-drawing.

To obtain a complete unit, please select the red components from the pages shown.

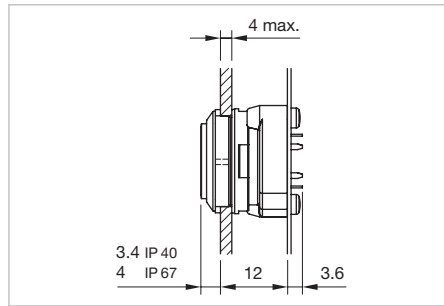

Dimensions



Product can differ from the current configuration.

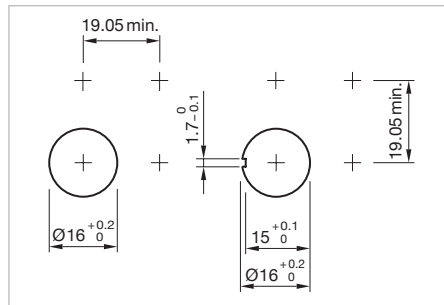

Mounting cut-outs

Front	Switching action	Part No.	Wiring diagram	Weight
				
Pushbutton actuator IP 67, square 18.8 x 18.8 mm				
Plastic white	B	92-340.000	1	0.003 kg
Plastic black	B	92-440.000	1	0.003 kg

Switching action: B = Momentary



Front

Lens plate IP 67

Additional Information

- Material plastic

Product attribute	Dimension	Pressure plate	Part No.	Weight
 <p>Lens plate for pushbutton and indicator IP 67</p>				
non-illuminative	12 x 12 mm	black opaque	92-941.000	0.001 kg
		grey opaque	92-941.800	0.001 kg
illuminative	12 x 12 mm	red transparent	92-941.200	0.001 kg
		orange transparent	92-941.300	0.001 kg
		yellow transparent	92-941.400	0.001 kg
		green transparent	92-941.500	0.001 kg
		blue transparent	92-941.600	0.001 kg
		colourless transparent	92-941.700	0.001 kg

Lens IP 40

Additional Information

- Material plastic
- With white marking plate

Product attribute	Dimension	Lens	Part No.	Weight
 <p>Lens for pushbutton and indicator IP 40</p>				
non-illuminative	13.2 x 13.2 mm	black opaque	92-956.000	0.001 kg
		grey opaque	92-956.800	0.001 kg
		white opaque	92-956.900	0.001 kg
illuminative	13.2 x 13.2 mm	red translucent	92-956.200	0.001 kg
		orange translucent	92-956.300	0.001 kg
		yellow translucent	92-956.400	0.001 kg
		green translucent	92-956.500	0.001 kg
		blue translucent	92-956.600	0.001 kg
		smoked transparent	92-958.100	0.001 kg
		red transparent	92-958.200	0.001 kg
		orange transparent	92-958.300	0.001 kg
		yellow transparent	92-958.400	0.001 kg
		green transparent	92-958.500	0.001 kg
		blue transparent	92-958.600	0.001 kg
		colourless transparent	92-958.700	0.001 kg

Bezel IP 40

Material	Colour	Part No.	Weight
 <p>Front bezel for pushbutton and indicator IP 40</p>	black	92-912.0	0.001 kg
	white	92-912.9	0.001 kg

Blind plug

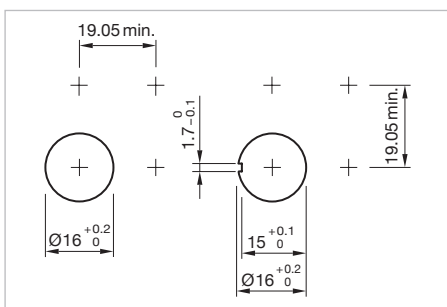

Mounting cut-outs

Dimension	Material	Colour	Part No.	Weight
 <p>Blind plug</p>	Plastic	black	51-948.0	0.003 kg

Rear side

Illumination element PCB

Additional Information

- The customer has to decide what series resistor shall be used to the LED

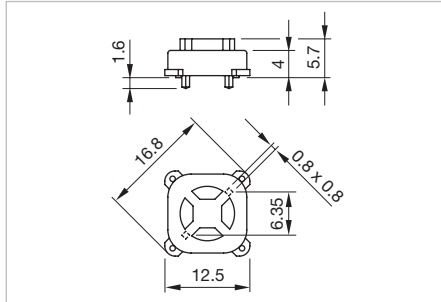

Dimensions

Terminal	Part No.	Component layout	Weight
 <p>Illumination element PCB mounting</p>			
PCB	92-800.042	1	0.001 kg

The component layouts you will find from page { $\$$ BR92_KAZE_Zeichnung}

Switching element PCB illuminative

Additional Information

- The customer has to decide what series resistor shall be used to the LED

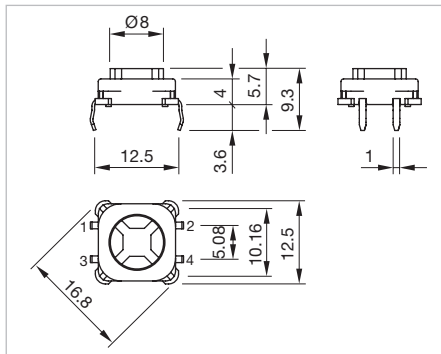

Dimensions

Contacts	Terminal	Part No.	Component layout	Wiring diagram	Weight
 <p>Switching element PCB mounting illuminative</p>					
1 NO	PCB	92-851.342	2	1	0.001 kg

The component layouts you will find from page { $\$$ BR92_KAZE_Zeichnung}

Mounting

Anti-twist ring

Additional Information

- For front panel thickness max. 2 mm

Mounting cut-out	Part No.	Weight
 <p>Anti-twist ring</p>		
Ø 16 mm	51-910	0.001 kg

Mounting flange

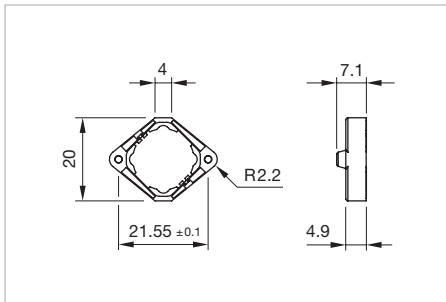

Dimensions

Part No.	Weight
 <p>Mounting flange</p>	
92-960.0	0.001 kg

Lens remover

Additional Information

- For lens IP 40 only

Part No.	Weight
 <p>Lens remover</p>	
18-910	0.002 kg